

ACTIVE ANTENNA ARRAY WITH OPTICAL INTERACTION FOR APPLICATION IN RADAR SYSTEM

Siou Teck Chew, Dennis T. K. Tong, Ming C. Wu, and Tatsuo Itoh

Department of Electrical Engineering
University of California, Los Angeles
405 Hilgard Avenue
Los Angeles, CA 90024

ABSTRACT

An active antenna array system, capable of switching between sum and difference patterns for radar applications, is explored. The desired phase relationship amongst antenna elements is synthesized via injection locking. Optical reference signal is transmitted from remote controller through optical fiber link. Measured patterns agree with theoretical results.

INTRODUCTION

In the conventional design approach, a radar system employs a high power transmitter, whose power is distributed to each antenna elements by bulky waveguide structures. The receiver also relies on the waveguide structure to combine the received power before mixing down to IF for signal processing. For tracking and beam-steering, phase shifters must also be included. Recently, there is a growing interest in active antenna system. Such system distributes the RF power handling and frequency conversion to each element of the active antenna. Currently, the main concentration of research in this area lies in power combining and beam-scanning of the transmitter [1-4].

In this paper, an attempt is made to design an active antenna array which not only provides quasi-optical power combining, but also beam-switching capability. The desired phase shift is derived through injection-locking. In this design, the concept of using optical link between the antenna platform and the remote controller unit is explored. Here, the optical signal is the

reference signal for injection-locking. This approach is favorable as optical fiber is low-loss, deformable, small, and light in weight. This system design can be equally applied to the receiver or T/R module configuration. The fiber link can carry control and data signals.

DESIGN

1. System configuration

The schematic diagram of the system setup is shown in Fig. 1. The active antenna array is the front-end while the reference signal generator is the remote controller unit. These two subsystems are linked by the optical system. The RF signal is first converted into optical signal by directly modulating a laser diode. The modulated optical signal is then launched into an optical fiber. The reference microwave signal is then recovered at the antenna through a high speed photodetector and amplifier. It is then fed into the active antenna array.

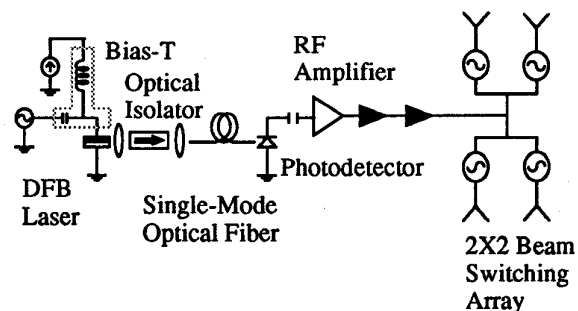

Figure 1 : System setup.

2. Optical Circuit

An InGaAsP-InP DFB distributed feedback (DFB) laser is used for direct modulation. It has been shown that DFB laser has a better relative intensity noise (RIN) than Fabry-Perot laser, and therefore better signal-to-noise ratio performance [5]. The laser is operating at 1.31 μm wavelength with a threshold current and external quantum efficiency of 24 mA and 0.25 W/A respectively. The measured 3 dB bandwidth of the laser, when biased at 60 mA, is 16 GHz. The laser is mounted on a coplanar waveguide with wire bonding. The coplanar waveguide is impedance matched to coaxial component. The operating temperature is maintained at 15°C. Light is collimated and focused by lenses into a standard single-mode fiber (SMF) with a core diameter of 9 μm . An optical isolator is inserted between the two lenses to avoid reflections. A high speed p-i-n photodetector (HP 83440) with a bandwidth of 34 GHz is used to detect and convert the optical signal into a RF signal.

For RF-to-optical conversion, a 10 dBm 6.6 GHz RF signal is injected into the laser via microwave probe. The average optical power in the SMF is -2.5 dBm when the laser is biased at 35 mA. A -33 dB link insertion loss is measured in this setup. This figure includes the coupling and detection loss. Better link efficiency can be achieved by improving fiber coupling efficiency and optical-RF conversion efficiency.

Amplifier is used to increase the power level to a sufficient level for injection locking before pumping the signal into the active antenna system.

3. Active Antenna Array

To achieve beam-switching, the phase difference $\Delta\phi$ of each quadrant of the phased array must be either 0° or 180°. This phase difference amongst the antennae is achieved through injection locking. Based on Kurokawa's theory [6], a phase difference of $\pm 90^\circ$ is possible. However, the phase difference is not varied continuously. Instead, the circuit switches between three phase difference states, namely $\Delta\phi = +90^\circ, -90^\circ$ and 0°.

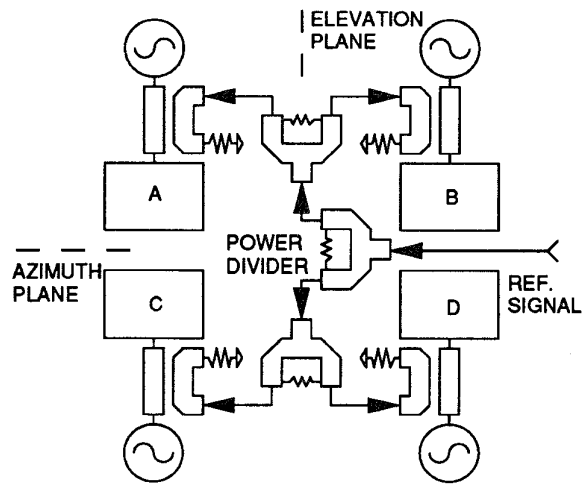

Figure 2 : Schematic diagram of the active antenna array.

The schematic diagram of the beam-switching array is shown in Fig. 2. The reference signal is divided in-phase and injected to the four oscillators. When all the oscillators are tuned to the injected frequency, a difference pattern is formed in the elevation plane. However, if oscillators A and B are tuned to the lower locking frequency and oscillators C and D are tuned to the upper locking frequency, a sum pattern is formed. Various combinations of the phase difference can result in sum or difference patterns in either planes.

This circuit is fabricated on substrate with $\epsilon_r = 2.33$ and thickness 30 mils. Wilkinson power divider is used for the power division. The oscillators are self-biased at $I_{DS} = 30\text{mA}$ with $V_{DS} = 3\text{V}$, operating at 6.6 GHz. The frequency is tuned independently via the drain bias and the tuning range is at least 40 MHz. The antenna elements are spaced $0.7 \lambda_o$, where λ_o is the wavelength at 6.6 GHz.

RESULTS

The measured sum and difference patterns of the beam-switching array in the azimuth plane are shown in Fig. 3a and 3b respectively. The measured patterns agree with theoretical results. The slight asymmetry of the peaks in Fig. 3b is

due to the power difference when a signal is locked from different free-running frequencies. The sum and difference patterns in the elevation plane are shown in Fig. 4a and 4b respectively. The distortion in the patterns is due to radiation from the rest of the circuit.

CONCLUSION

In this paper, an attempt to integrate a RF active antenna array with optical input for radar applications has been made and demonstrated. The reference signal is transmitted via an optical fiber link and recovered through a photodetector. The system can switch between sum and difference patterns bi-directionally. This design can be further integrated for T/R module with ranging and tracking capabilities.

ACKNOWLEDGMENT

This work is supported by US Army Research Office under contract DAAH04-93-G-0068 and in part by the Joint Services Electronics Program F49620-92-C-0055.

REFERENCE

- [1] K. D. Stephan, "Inter-injection-locked oscillators for power combining and phased arrays," *IEEE Trans. Microwave Theory Tech.*, vol. MTT-34, pp. 1017-1025, Oct. 1986.
- [2] J. Birkeland and T. Itoh, " Spatial power combining using push-pull FET oscillators with microstrip patch resonators," *1990 IEEE MTT-S Int. Microwave Symp. Dig.*, vol. 3, pp.1217-1220, 1990.
- [3] J. Lin, S. T. Chew, and T. Itoh, "A Unilateral Injection-locking Type Active Phased Array for beam-scanning," *1994 IEEE MTT-S Int. Microwave Symp. Dig.*, vol. 2, pp. 1231-1234, 1994.
- [4] P. Liao and R. A. York, "Phase-shifterless beam-scanning using coupled-oscillators : theory and experiment," *1993 IEEE AP-S Int. Symp. Dig.*, Vol. 2, pp.668-671, 1993.
- [5] K. Y. Lau, C. M. Gee, T. R. Chen, N. bar-Chaim, and I. Urym, "Signal-Induced Noise in Fiber-Optic Links using Directly-Modulated Fabry-Perot and Distributed-Feedback Laser Diodes," *J. Lightwave Technol.*, vol. 11, pp. 1216-1225, 1993.
- [6] K. Kurokawa, "Injection locking of microwave solid-state oscillators," *Proceedings of IEEE*, vol. 61, pp. 1386-1410, Oct. 1973.

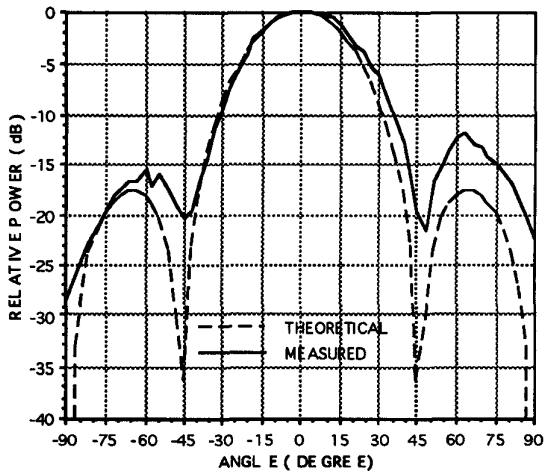

Figure 3a : Sum pattern in the azimuth plane.

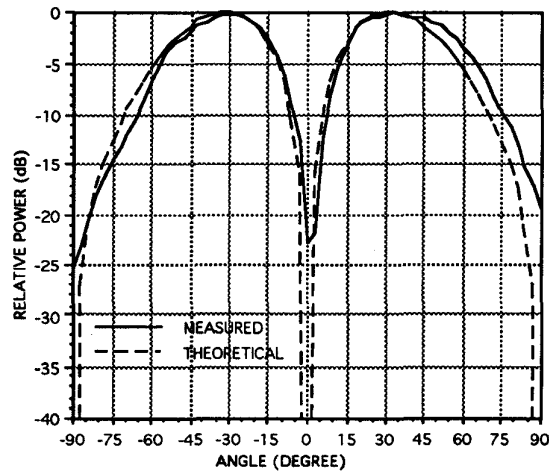

Figure 3b : Difference pattern in the azimuth plane.

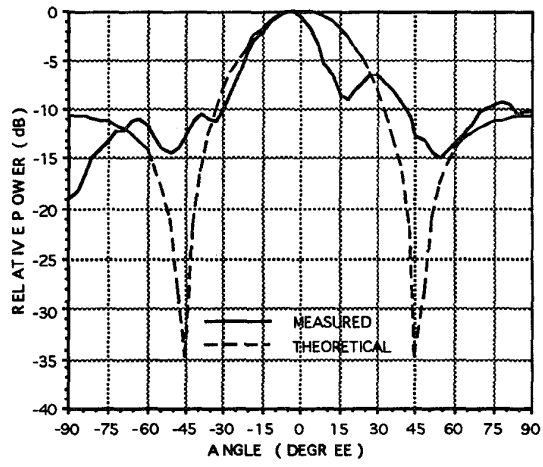

Figure 4a : Sum pattern in the elevation plane.

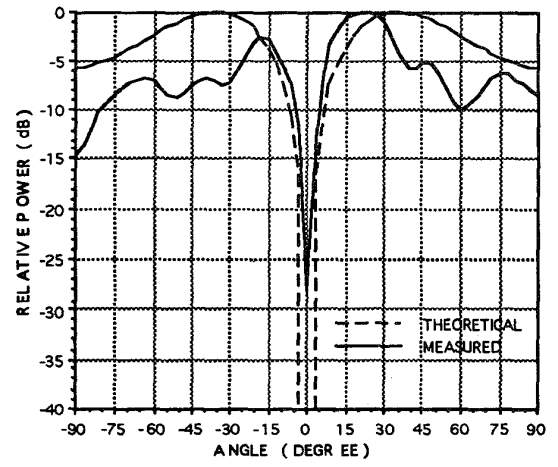

Figure 4b : Difference pattern in the elevation plane.