

Tunable Monolithic Colliding Pulse Mode-Locked Quantum-Well Lasers

M. C. Wu, Y. K. Chen, T. Tanbun-Ek, R. A. Logan, and M. A. Chin

Abstract—The tunabilities of both the wavelength and the pulse width of monolithic mode-locked semiconductor lasers are demonstrated for the first time. Pulses shorter than 1.6 ps, tunable over 8.8 nm, have been generated by a temperature-tuned monolithic colliding pulse mode-locked (CPM) quantum-well laser. For a fixed wavelength, the pulse width is independently controlled from 1.2 ps to longer than 3 ps by external bandpass filters. Near transform-limited time-bandwidth products of 0.34 are maintained throughout the tuning processes.

THE combination of mode-locked lasers generating transform-limited pulses at 1.55 μm [1]–[5] and erbium-doped fiber amplifiers (EDFA) have generated a great deal of interests in many applications, including optical soliton transmissions [6], [7], nonlinear optical logic devices [8], electrooptical sampling, and millimeter-wave generations. In many of these applications, tuning of both the wavelength and the pulse width are highly desirable. For example, in optical solitons, the peak power P_1 and the pulse width τ satisfy the relation $P_1\tau^2 = \gamma|\lambda_C - \lambda_D|$ where γ is a constant depending on the fiber properties, λ_C is the signal center wavelength, and λ_D is the zero dispersion wavelength of the fiber [9]. The freedom of tuning λ_C and τ allows the soliton parameters to be properly optimized. Furthermore, with two or more tunable mode-locked lasers, multicolor solitons can be transmitted simultaneously [7].

In mode-locked lasers with external cavities, the wavelength and the pulse width can be mechanically tuned by grating feedback elements or intracavity filters [5], [10]. However, these structures are bulky and suffer from excessive losses, and the tuning is usually accompanied by realignment of the optical cavity. On the other hand, monolithic mode-locked semiconductor lasers are compact and stable sources of short optical pulses [1]–[3], [11]. Their capabilities of generating transform-limited pulses were first demonstrated by monolithic colliding pulse mode-locked (CPM) quantum-well lasers [2], [3]. However, the tuning capabilities of the monolithic mode-locked semiconductor lasers have not been studied. In this letter, we report, for the first time, the tunability of both the wavelength and the pulse width of the monolithic mode-locked semiconductor lasers. Pulses shorter than 1.6 ps are generated over a broad wavelength range, 1.528 ~ 1.537 μm , using a temperature-tuned mono-

lithic CPM laser. The tuning range of 8.8 nm is limited by the gain bandwidth of the EDFA. At a fixed wavelength, the pulse width is independently controlled by external bandpass filters. The time-bandwidth products of the pulses remain unchanged (~ 0.34) throughout the tuning processes.

A schematic of the experimental arrangement is shown in Fig. 1. A monolithic InGaAs/InGaAsP CPM quantum well laser generating picosecond optical pulses at 80 GHz repetition rate is used as the optical source. The output pulses are coupled into an optical fiber and then amplified by a 1480-nm diode-pumped EDFA. Optical isolators are placed on both sides of the EDFA to prevent reflections back to the CPM laser and to suppress lasing in the EDFA. The pulse width and the optical spectrum are monitored simultaneously with a noncollinear second-harmonic autocorrelator and an optical spectrum analyzer. The wavelength of the CPM laser is designed to be 1.53 μm , matching the gain spectrum of the EDFA. The detailed device structures have been reported previously. The center section of the CPM laser ($\sim 50 \mu\text{m}$ long) is reverse biased as saturable absorber, while the rest of the laser is forward biased as gain media. Under normal passive mode-locking conditions (gain section current $I_G = 100 \text{ mA}$, saturable absorber voltage $V_{\text{sat}} = -0.5 \text{ V}$, and heat sink temperature $T = 18^\circ\text{C}$), the CPM laser generates pulses with a duration of 1.28 ps, a time-bandwidth product of 0.34, and a peak power of 5 mW. The EDFA operates in gain-saturation regime and provides 20 dB gain at an average input power of -8 dBm . The peak power of the amplified pulses is 160 mW.

To implement the tuning schemes similar to those in external-cavity mode-locked lasers, sophisticated fabrication technologies such as those used in photonic integrated circuits [12] need to be used. On the other hand, the well-known temperature dependence of the semiconductor energy bandgap provides a convenient way to tune the wavelength of the monolithic mode-locked lasers, taking advantage of the mechanical stability of the integrated optical cavities with temperature changes. Fig. 2 shows the second-harmonic autocorrelation traces and the corresponding time-averaged optical spectra of the CPM pulses for three laser (heat sink) temperatures: (a) $T = 11^\circ\text{C}$, (b) $T = 18^\circ\text{C}$, and (c) $T = 25^\circ\text{C}$. The spectral envelop shifts continuously toward the longer wavelength side with increasing temperature, and λ_C moves from 1528.4 nm ($R = 11^\circ\text{C}$) to 1537.2 nm ($T = 25^\circ\text{C}$). The spectral envelopes are smooth and symmetric at all temperatures, indicating that the modes are well locked over the entire wavelength tuning range. The autocorrelation traces

Manuscript received June 17, 1991; revised August 2, 1991.
The authors are with AT&T Bell Laboratories, Murray Hill, NJ 07974.
IEEE Log Number 9103320.

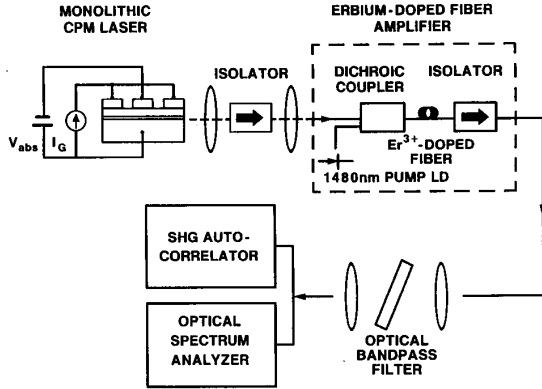

Fig. 1. The experimental arrangement for the tunable monolithic CPM quantum well laser.

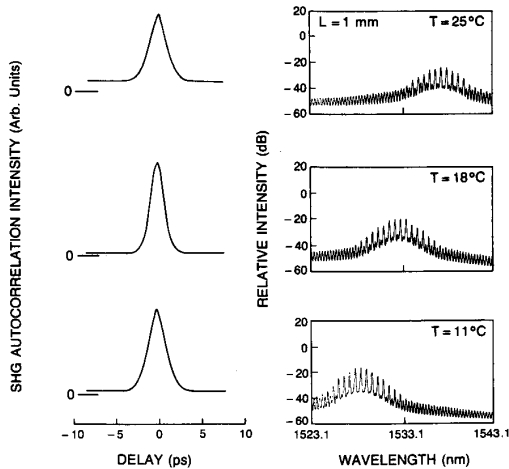

Fig. 2. The autocorrelation traces and the corresponding optical spectra of the CPM pulses for laser heat sink temperatures of (a) 11°C, (b) 18°C, and (c) 25°C.

agree very well with those of sech^2 pulse shapes, and have full-width-at-half-maximum (FWHM) pulse widths of (a) 1.62 ps, (b) 1.30 ps, and (c) 1.62 ps. Near 100% intensity modulation is obtained. At high temperature, the signal power decreases and the amplified spontaneous emission noise from the EDFA contributes to the background of the autocorrelation traces.

The variations of the pulse width versus the center wavelength are shown in Fig. 3. The laser temperature is also shown in the same figure. The inset shows the amplified spontaneous emission (ASE) spectra of the EDFA for various 1480 nm pump powers. The ASE power in the signal band at the output fiber is lower than the signal power by 15 dB, giving a very good signal-to-noise ratio. The ASE has a peak at 1.53 μm and a broad plateau around 1.56 μm . The experimental wavelength tuning range of the CPM laser is marked on the ASE curves. The total tuning range exceeds 8.8 nm, limited by the gain bandwidth of the EDFA at the 1.53 μm peak. Wider tuning range can be expected if the

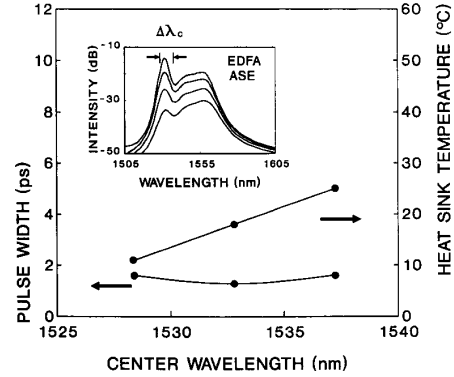

Fig. 3. The pulse width and the laser heat sink temperature versus the center wavelength of the mode-locked pulses. The inset shows the ASE spectra of the EDFA for various pump powers. The total wavelength tuning range, $\Delta\lambda_C$, limited by the gain bandwidth of the EDFA, exceeds 8 nm.

laser operates around the 1.56- μm plateau. The wavelength tuning rate of $d\lambda_C/dT = 0.63 \text{ nm}/^\circ\text{C}$ is slightly larger than that of a Fabry-Perot laser ($d\lambda/dT \approx 0.5 \text{ nm}/^\circ\text{C}$) [13]. The difference mainly results from the extra current applied to the laser at high temperatures, which introduces further heating in the p-n junction [14]. The pulse width has a minimum of 1.3 ps at 1532.8 nm, the gain peak of the EDFA. The parabolic dependence of the pulse width on wavelength indicates that the gain spectrum of the EDFA limits the spectral bandwidth of the CPM pulses as the center wavelength is tuned away from the gain peak of the EDFA. As a result, the pulse width increases to 1.6 ps at $\lambda_C = 1528.4$ and 1537.2 nm. Nevertheless, the time-bandwidth products of the amplified pulses are 0.37, 0.34, 0.35 for $\lambda_C = 1528.4$, 1532.8, and 1537.2 nm, respectively, which are very close to the transform-limited value of 0.31.

The pulse widths of the tunable CPM lasers are further adjusted by spectral windowing with external bandpass filters (BPF's) if broader pulses are desired, as in the case of optical solitons. Fig. 4 shows the autocorrelation traces and the corresponding optical spectra of the filtered CPM pulses. The pulse width is increased by inserting filters with various bandwidths ($\Delta\lambda_{\text{BPF}}$), and FWHM widths of 1.6, 1.8, and 2.9 ps are obtained for $\Delta\lambda_{\text{BPF}} = 4, 2.4, \text{ and } 1 \text{ nm}$, respectively. The pulse width can be approximated by

$$\tau = (\tau_0 \Delta\lambda_0) \sqrt{\frac{1}{\Delta\lambda_0^2} + \frac{1}{\Delta\lambda_{\text{BPF}}^2}} \quad (1)$$

where τ_0 and $\Delta\lambda_0$ are the pulse width and the spectral bandwidth, respectively, in the absence of the filters. The experimental pulse width agrees very well with the calculated value, as shown by the solid line in Fig. 5. Near transform-limited time-bandwidth product (~ 0.34) is maintained for different filter bandwidth (Fig. 5). This is in sharp contrast to the spectral filtering of gain-switched laser pulses. Because the pulses generated by the gain-switched lasers are highly chirped, very narrow filter bandwidth is required to obtain near transform-limited pulses. For example, a filter bandwidth of 0.2 nm is required to reduce the time-bandwidth

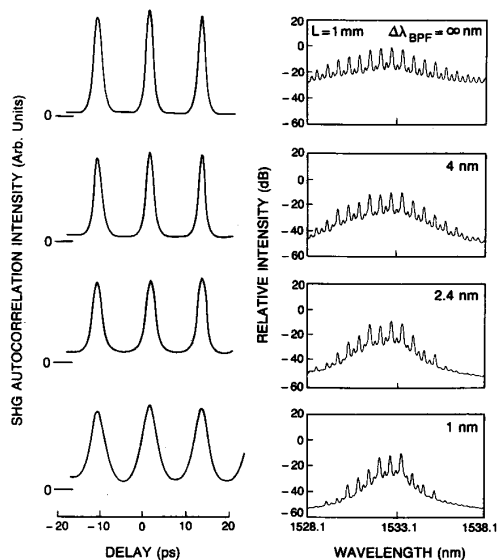

Fig. 4. The autocorrelation traces and the corresponding optical spectra of the filtered CPM pulses for various filter bandwidth ($\Delta\lambda_{\text{BPF}}$) of ∞ , 4, 2.4, and 1 nm, respectively.

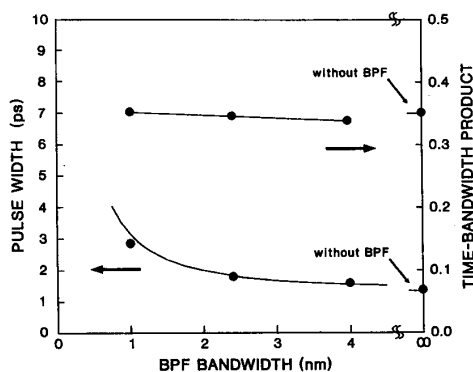

Fig. 5. The pulse width and the time-bandwidth product of the filtered CPM pulses versus the bandwidth of the bandpass filters ($\Delta\lambda_{\text{BPF}}$).

product to 0.45, as reported in [15]. Here, the transform-limited pulses is already achieved by the CPM laser alone, and the filter bandwidth can be freely selected to tailor the desired pulse width without affecting the time-bandwidth product.

In summary, the tunability of both the wavelength and the pulse width of monolithic mode-locked semiconductor lasers are demonstrated for the first time. Pulses shorter than 1.6 ps and tunable from 1528 to 1537 nm have been achieved using a temperature-tuned monolithic colliding pulse mode-locked (CPM) laser. The 8.8-nm wide tuning range is at present

limited by the gain bandwidth of the erbium-doped fiber amplifier at 1.53 μm . At a fixed wavelength, the pulse width is independently controlled by an external bandpass filter. In all cases, the time-bandwidth product remains near transform-limited.

ACKNOWLEDGMENT

The authors would like to thank Dr. J. R. Simpson and Dr. G. Nykolak for the help with the erbium-doped fiber amplifiers.

REFERENCES

- [1] R. S. Tucker, U. Koren, G. Raybon, C. A. Burrus, B. I. Miller, T. L. Koch, G. Eisenstein, and A. Shahar, "40 GHz active mode-locking in a 1.5 μm monolithic extended cavity laser," *Electron. Lett.*, vol. 25, pp. 621-622, May 1989.
- [2] M. C. Wu, Y. K. Chen, T. Tanbun-Ek, R. A. Logan, M. A. Chin, and G. Raybon, "Transform-limited 1.4 ps optical pulses from a monolithic colliding-pulse mode-locked quantum well lasers," *Appl. Phys. Lett.*, vol. 57, pp. 759-761, Aug. 1990.
- [3] Y. K. Chen, M. C. Wu, T. Tanbun-Ek, R. A. Logan, and M. A. Chin, "Subpicosecond monolithic colliding pulse mode-locked multiple quantum well lasers," *Appl. Phys. Lett.*, vol. 58, pp. 1253-1255, Mar. 1991.
- [4] K. Smith, J. R. Armitage, R. Wyatt, N. J. Doran, and S. M. J. Kelly, "Erbium fibersoliton laser," *Electron. Lett.*, vol. 26, pp. 1149-1151, Aug. 1990.
- [5] D. M. Bird, R. M. Fatah, M. K. Cox, P. D. Constantine, J. C. Regnault, and K. H. Cameron, "Miniature packaged actively mode-locked semiconductor laser with tunable 20 ps transform-limited pulses," *Electron. Lett.*, vol. 26, pp. 2086-2087, Dec. 1990.
- [6] L. Mollenauer, M. J. Neubelt, S. G. Evangelides, J. P. Gordon, and J. R. Simpson, in *Proc. Conf. Lasers Electro-Optics*, (Opt. Soc. Amer., Washington, DC, 1990) postdeadline paper PDP-17.
- [7] N. A. Olsson, P. A. Andrekson, J. R. Simpson, T. Tanbun-Ek, R. A. Logan, and K. Wecht, "Two-channel soliton pulses propagation over 9000 km with 10^{-9} bit-error rate," in *Optical Fiber Commun. Conf.*, (Opt. Soc. Amer., Washington, DC, 1991), postdeadline paper PD-1.
- [8] M. N. Islam, C. E. Socolich, and D. A. B. Miller, "Low-energy ultrashort fiber soliton logic gates," *Opt. Lett.*, vol. 15, pp. 909-911, Aug. 1990.
- [9] A. Hasegawa, *Optical Solitons in Fibers*, 2nd ed. New York: Springer-Verlag, 1990, p. 39.
- [10] J. M. Wiesenfeld, M. Kuznetsou, and A. S. Hou, "Tunable, picosecond pulse generation using a compressed mode-locked laser diode source," *IEEE Photon. Technol. Lett.*, vol. 2, pp. 319-321, May 1990.
- [11] K. Y. Lau, "Narrow-bandwidth modulation of semiconductor laser at millimeter wave frequencies (> 100 GHz) by mode-locking," *IEEE J. Quantum Electron.*, vol. QE-26, pp. 250-261, Feb. 1990.
- [12] T. L. Koch and U. Koren, "Semiconductor photonic integrated circuits," *IEEE J. Quantum Electron.*, vol. 27, pp. 641-654, 1991.
- [13] G. P. Agrawal and N. K. Dutta, *Long-Wavelength Semiconductor Lasers*. New York: Van Nostrand Reinhold, 1986, p. 316.
- [14] M. Kitamura, H. Yamazaki, T. Ono, T. Sasaki, N. Hamano, T. Numai, S. Yamazaki, H. Yamada, and I. Mito, "High power and narrow linewidth 1.5 μm MQW-DFB-LD with low FM dip frequency," in *Proc. Conf. Lasers and Electro-Optics*, Opt. Soc. America, Washington, DC, 1990, paper CTHA-5, p. 342.
- [15] M. Nakazawa, K. Suzuki, and Y. Kimura, "Transform-limited pulse generation in the giga hertz region from a gain-switched distributed feedback laser diode using spectral windowing," *Opt. Lett.*, vol. 15, pp. 715-717, June 1990.